

FS-4 & SS-4 STEEL LID

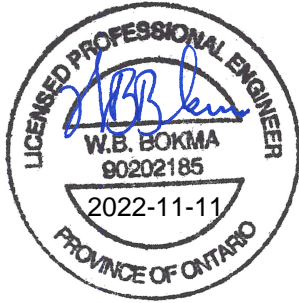

SAFE LIFTING CAPACITY = 5,400 lbs. (2,450 kg.)

MTE Consultants Inc. Project No. 51787-100
For the confirmation of the safe lifting capacity.
Factor of Safety = 2.5
Inclination of lifting slings/chains shall not be less than 64° from the horizontal (see below).

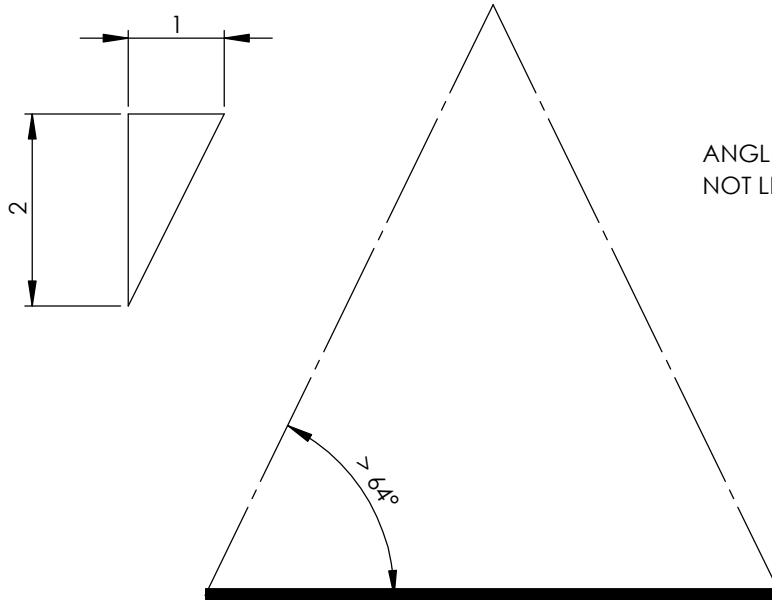

ANGLE OF LIFTING SLINGS
NOT LESS THAN 64 DEGREES.

FS-4 & SS-4 STEEL LID

FS-4 ASSEMBLY DETAILS

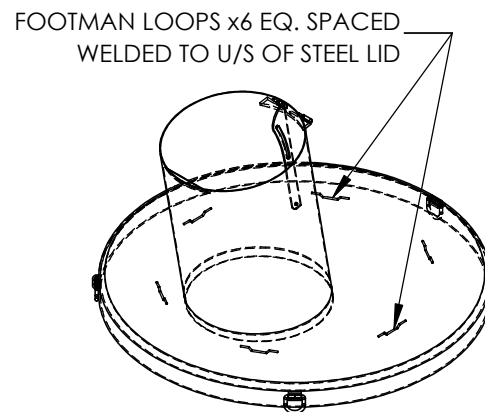
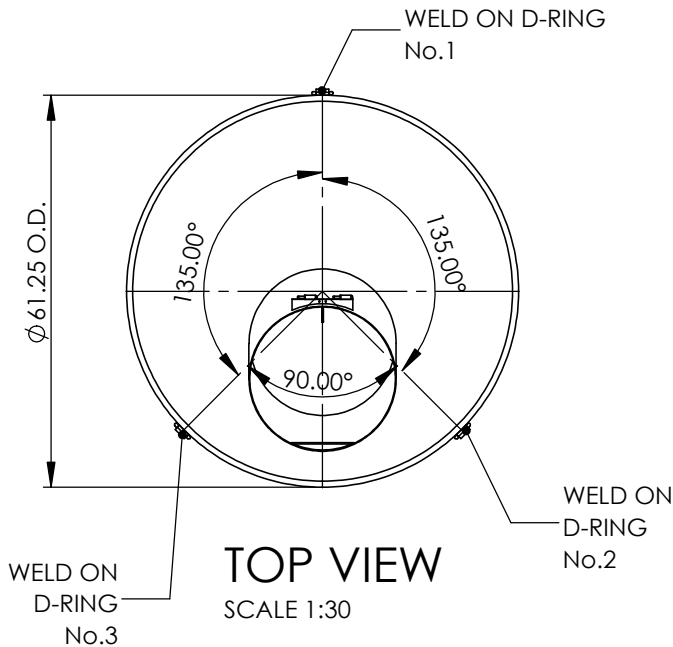

ISOMETRIC VIEW
SCALE 1:30

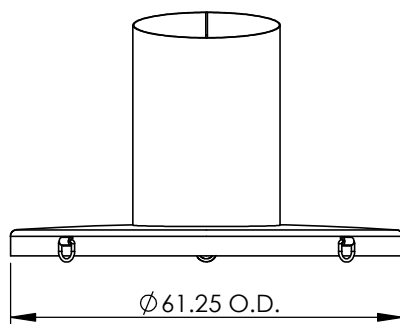

FRONT VIEW
SCALE 1:30

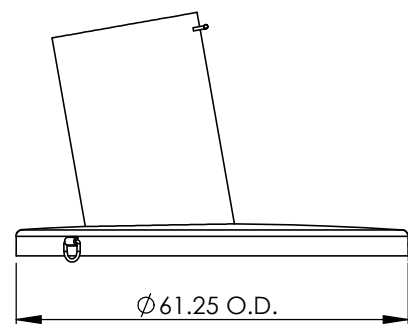

SIDE VIEW
SCALE 1:30

NOTES:

1. ALL DIMENSIONS ARE SHOWN IN IMPERIAL UNLESS OTHERWISE NOTED
2. MATERIAL: G44W GRADE MINIMUM CARBON STEEL
3. THICKNESS: 0.25"
4. ALL WELDED CONNECTIONS
5. REUSABLE BAG IS SUSPENDED FROM FOOTMAN LOOPS AT 6 EQUAL LOCATIONS WITH QUICK LINK CONNECTIONS

FS-4 & SS-4 STEEL LID

SS-4 ASSEMBLY DETAILS

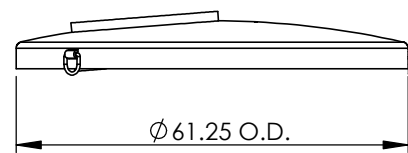
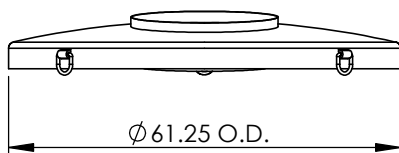
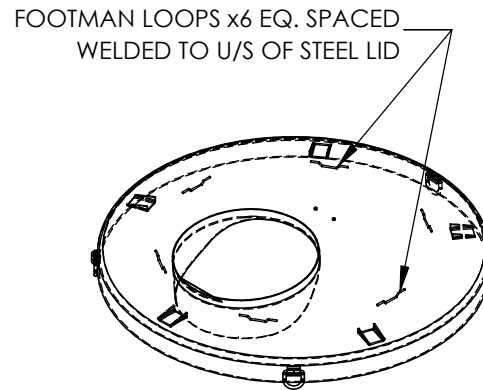
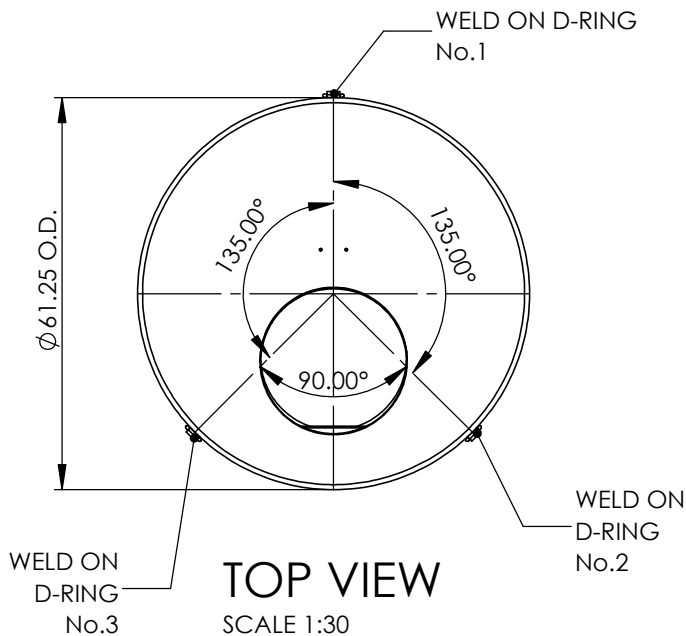

NOTES:

1. ALL DIMENSIONS ARE SHOWN IN IMPERIAL UNLESS OTHERWISE NOTED
2. MATERIAL: G44W GRADE MINIMUM CARBON STEEL
3. THICKNESS: 0.25"
4. ALL WELDED CONNECTIONS
5. REUSABLE BAG IS SUSPENDED FROM FOOTMAN LOOPS AT 6 EQUAL LOCATIONS WITH QUICK LINK CONNECTIONS

FS-4 & SS-4 STEEL LID

WELD ON D-RING DETAILS

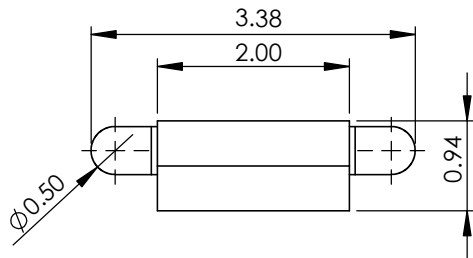

TOP VIEW

SCALE 1:2

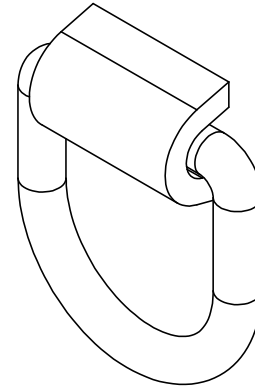

ISOMETRIC VIEW

SCALE 1:2

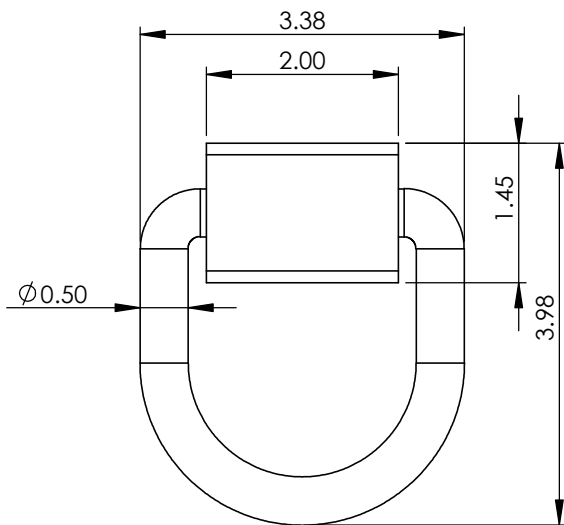

FRONT VIEW

SCALE 1:2

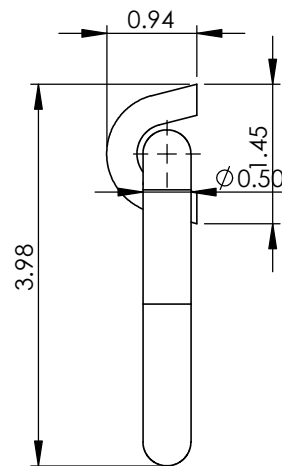

SIDE VIEW

SCALE 1:2

FS-4 & SS-4 STEEL LID

FOOTMAN LOOP DETAILS

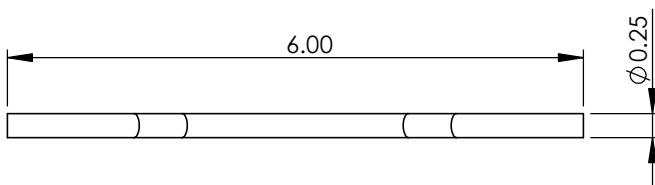

TOP VIEW

SCALE 1:2

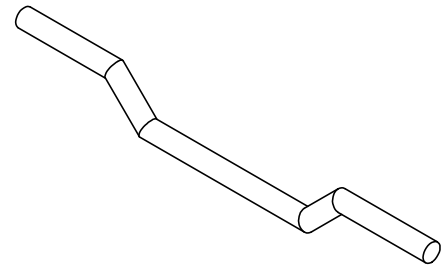

ISOMETRIC VIEW

SCALE 1:2

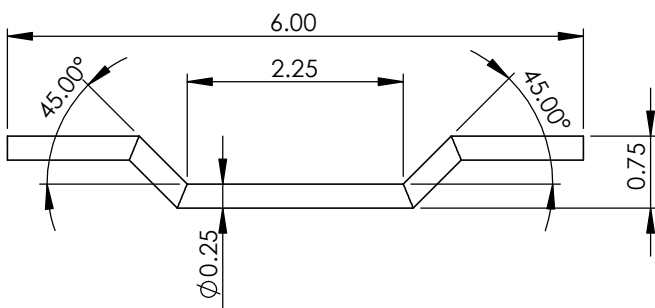

FRONT VIEW

SCALE 1:2

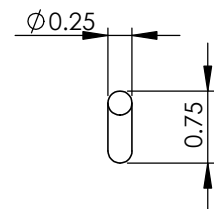

SIDE VIEW

SCALE 1:2